

Radio receiver module NBFP490 with master radio key

Installation, operation and
maintenance instructions



These instructions are to
be passed on by the fitter
to the user



Instructions in further languages,
refer to www.fuhr.de



1 Application

The radio receiver module NBFP490 is a rolling code radio receiver for opening FUHR **multitronic 881** and **autotronic 834(P)** motorised lock systems, by means of up to max. 25 different radio keys.

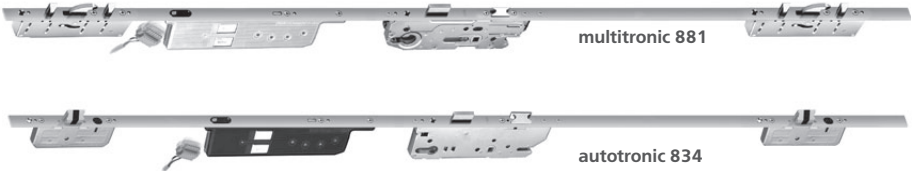

The radio receiver is compatible with all conventional FUHR transmitter modules: radio key, radio wall-mounted push-button switch, radio transponder reader, radio fingerprint scanner, radio keypad.



Radio key
NZ80062



Wall-mounted
push-button switch
NZ80021AS



Transponder
NB403/NB540/
NB688N/NB693N



Fingerprint
scanner
NB366B/
NB649N



Keypad
NB404

2 Delivery scope

Radio receiver with connection cable



Master radio key, 3 channels



3 Positioning

The radio receiver is inserted behind the lock faceplate at the top end of the 881-/834-drive unit and connected with the enclosed 3-core connection cable to the drive unit's green coupler.

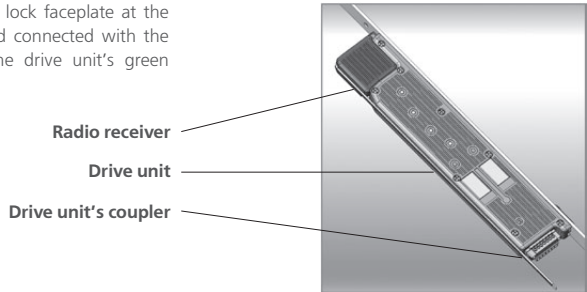

4 Installation requirements

The following FUHR motorised locks' components have been modified from the manufacturing date April 2010, in order to facilitate the installation of the radio receiver:

1. Opening for the LED tune-in button in the lock faceplate
2. Insertion device on the drive unit

Motorised locks that are not equipped with both of these modifications are unsuitable for installing these radio receivers. For this purpose please use a control unit on the frame with integrated radio receiver.

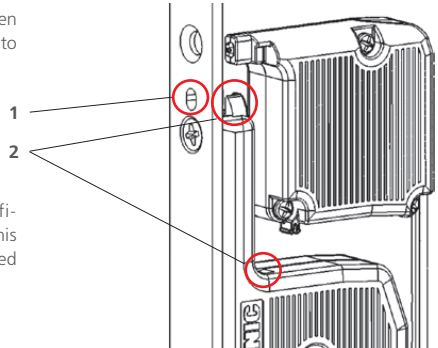

5 Installation dimensions

The module fits into the 280 mm long drive unit's standard routing.

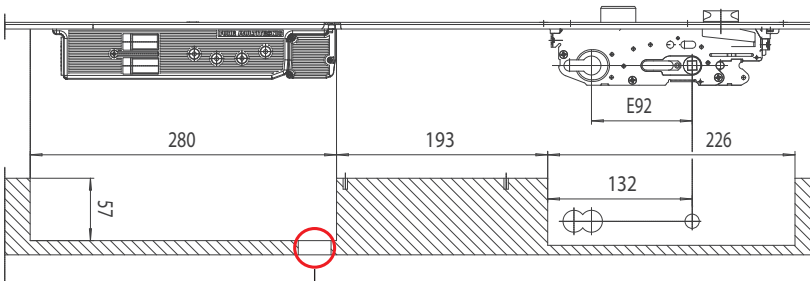

Tip: On metal door leaves, the reception range can be increased by notching out the profile wall towards the glazing rebate area behind the radio receiver modul.

6 Installation and component description

The radio receiver module NBF490 (1) has a transparent tune-in button with a red indicator LED (2) to tune in the FUHR radio transmitter, as well as a 3-core connection cable (3) to be connected to the drive unit with the green coupler.

To position and fix the drive unit, the radio-controlled module's housing is equipped with an insertion channel (4) and a catch spring (5). The drive unit is equipped with appropriate mounting areas* (6). Slide the radio receiver module downwards along the insertion channel until the catch spring in the motor drive's housing positively engages into place.

There is an opening* (7) in the lock faceplate located above of the drive unit, through which one can activate the LED tune-in button (2) in a built-in state from the outside. This LED tune-in button must be pressed first for disassembly, before the radio receiver module can be removed towards the top.

* From date of manufacture: 04/2010

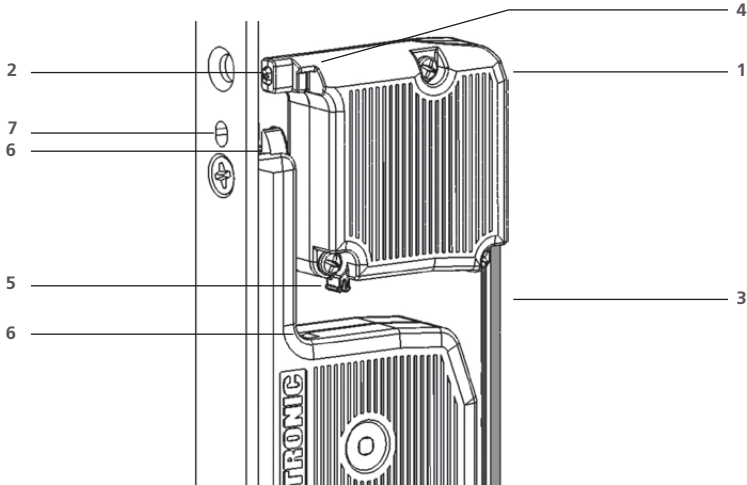

Activate the LED tune-in button in the inserted position:

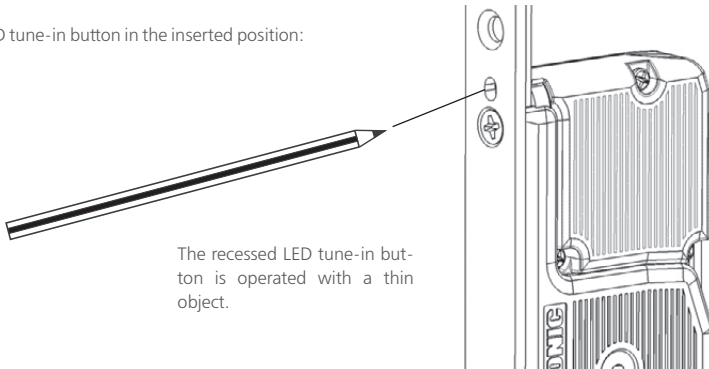

The recessed LED tune-in button is operated with a thin object.

Three cables are located on the back of the radio receiver: white, brown & green. Please connect these three cables in the correct order to the following screw terminals on the drive unit's coupler:

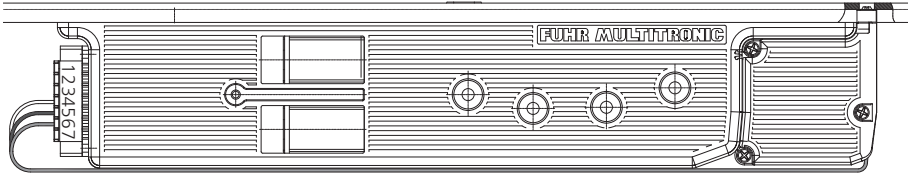

Terminal 4 – white cable
Terminal 5 – brown cable
Terminal 6 – green cable

After the motorised lock's 12 V DC power supply has been connected (terminal 2-3 refer to installation instructions 881/834), the radio receiver is operational.

7 Master radio key

The radio receiver distinguishes between **master keys** and **user keys**.



The **master key** is always unique! It cannot be deleted, replaced or modified. More user keys can be tuned in to the radio receiver with it, or alternatively user keys can also be deleted. The master key is a one-off and under no circumstances may it be lost! It is also suitable for opening the door.

Your radio receiver is supplied with a factory tuned in master key. You recognise the master key by the three **red** control keys.

The tuned in master button is located in the centre. Both of the other buttons are unallocated transmission buttons (e.g. for garage door drive units etc.).

You can immediately emit a radio signal to open the door with the master key. The LED tune-in button lights up for 2 seconds, if the applicable signal is detected.

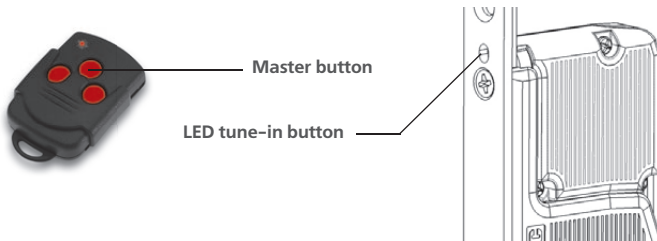

8 User keys

Apart from the previously tuned in master key, up to 25 user keys can be tuned in to the radio receiver. The user keys serve only to open the door; they have no tuning in or deleting authorisation.

All FUHR radio transmitters are suitable as user transmitters: radio key, radio fingerprint scanner, radio transponder, radio keypad and radio wall-mounted push-button switch.

Tuning in new user keys in to the radio receiver

1. Activate the radio receiver's LED tune-in button **briefly (<1 second)**.
 - The LED tune-in button flashes slowly.
2. Press the **master key's** centre, red transmitter button **once** within 20 seconds.
 - As soon as the radio receiver accepts the master, the radio receiver's LED tune-in button lights up for approx. 2 seconds and then continues to flash slowly.
3. Press the new **user key's** transmitter button **twice consecutively** within 20 seconds!
 - As soon as the radio receiver detects and saves the new user key, the LED tune-in button on the radio receiver lights up for 4 seconds and then goes out automatically.
 - The user key can now be used to open the door.
4. The tuning in procedure is aborted if the 20 second time limit is exceeded or if an incorrect master key is used.

Deleting specific individual user keys from the memory

If you would like to remove the opening authorisation from a previously tuned in user key, you can delete this specifically from the radio receiver's memory. To do so, please proceed as follows:

1. Press the radio receiver's LED tune-in button **for longer than 3 seconds**.
 - The LED begins to flash fast
 - Release the button.
2. Press the **master key's** transmission button **once** within 20 seconds.
 - As soon as the radio receiver accepts the master, the radio receiver's LED tune-in button lights up for approx. 2 seconds and then continues to flash quickly.
3. Press the **user key** to be deleted **once** within 20 seconds.
 - If the LED tune-in button lights up for approx. 4 seconds, the respective transmission code is deleted.
4. Check using the user key, as to whether the delete process was successful!

Deleting all user keys completely from the radio receiver's memory

If you would like to remove the opening authorisation from all previously tuned in user keys, you can delete the radio receiver's memory completely. Only the master key remains active. To do so, please proceed as follows:

1. Press the radio receiver's LED tune-in button **for longer than 3 seconds**.
 - The LED begins to flash fast
 - Release the button.
2. Press the **master key's** transmission button **once** within 20 seconds.
 - As soon as the radio receiver accepts the master, the radio receiver's LED tune-in button lights up for approx. 2 seconds and then continues to flash quickly.
3. Press the radio receiver's LED tune-in button again **for longer than 3 seconds**.
 - If the LED tune-in button lights up for approx. 4 seconds, all transmission codes – with the exception of the master – are deleted.



In order to rule out the possibility of anyone else except the authorised end customer tuning in a user key, we recommend end customers to carry out this deletion process immediately after receiving the master key!

9 Technical data

Radio receiver

Frequency:	868.3 MHz
Modulation:	FSK (frequency shift keying)
Security:	Rolling code with master transmission principle
Aerial:	On board
Power supply:	12 V DC
Current consumption:	15 mA
Operating control:	Red light emitting diode (LED)
Temperature range:	-10°C to +50°C
Dimensions:	43 x 40 x 15 mm
Connection cable:	3-core, approx. 320 mm long
Weight:	approx. 50 g
IP rating:	IP 20
Switching impulse:	Potential-free

Master radio key

The hand-held transmitters conform to the R&TTE guideline 1999/5/EG

Frequency:	868.3 MHz
Modulation:	FSK (frequency shift keying)
Security:	Rolling code
Channels:	3
Power supply:	1 x 3 V battery, CR 2032
Operating control:	Red light emitting diode (LED)
Temperature range:	-10°C to +50°C
Dimensions:	53 x 36 x 15 mm
Weight:	approx. 20 g

Changing the radio key battery

1. Open the housing with a coin.
2. Slide out the battery downwards.



3. Insert the new CR2032 battery, with the + pole pointing upwards.
4. Press the casing together again.



10 The radio receiver's LED signals

The following LED signals can only be checked after applying the 12 V DC power supply.

- The LED tune in button lights up permanently ➤ A master key has not been tuned in yet. **Please note:** The first radio transmitter tuned in is the future master radio transmitter!
- The LED tune in button lights up for 2 seconds ➤ A previously tuned in transmission signal has been picked up, the lock unlocks motor-driven.
- The LED tune in button lights up for 0.5 seconds ➤ A transmission signal that has not been tuned in yet has been picked up, the lock does not unlock.
- The LED tune in button doesn't light up at all ➤ The LED does not light up in the non-actuated original position, as no transmission signal has been picked up. Should the LED not light up despite transmitting an opening signal, the radio receiver and/or the motor lock have not yet been connected to the 12 V DC operating voltage or the cables on the drive unit's coupler have been connected incorrectly.

11 Safety instructions, maintenance and care

The radio receiver module is maintenance-free. If the radio key's transmitter range deteriorates, please replace the battery.

The supplied components are to be protected against humidity. They are not suitable for areas with high humidity and chemical substances!

Only original FUHR accessories may be used. We accept no liability for incorrect installation or operation. The housings and cables are to be protected against mechanical damage. Damaged or faulty components must be decommissioned and replaced immediately.